

Part Number: PT925-35170 (D-Cab)
PT925-35172 (C-Cab)

Kit Contents

| Item # | Quantity Req'd. | Description |
|--------|-----------------|----------------------|
| 1 | 1 | Left Hand Step Tube |
| 2 | 1 | Right Hand Step Tube |
| 3 | 1 | Hardware Kit |
| | | |

Hardware Bag Contents

| Item # | Quantity Req'd. | Description |
|--------|-----------------|----------------------|
| 1 | 12 | SEMS 8mm x 30mm Bolt |
| 2 | | |
| 3 | | |
| | | |

Additional Items Required For Installation

| Item # | Quantity Req'd. | Description |
|--------|-----------------|-------------|
| 1 | | |
| 2 | | |
| 3 | | |
| | | |

Conflicts

| |
|---------------------------|
| Regular/Access Cab Models |
|---------------------------|

Recommended Tools

| Personal & Vehicle Protection | Notes |
|-------------------------------|------------------------------|
| | |
| | |
| | |
| Special Tools | Notes |
| | |
| | |
| Installation Tools | Notes |
| 12mm Socket | |
| Ratchet | |
| Torque Wrench | 0-50 N-m (0-37 ft-lbf) |
| Panel Pry Tool | Toyota SST 00002-06001-01 |
| Special Chemicals | Notes |
| | |
| | |
| | |

General Applicability

| |
|----------------------|
| D-Cab & C-Cab Models |
|----------------------|

Recommended Sequence of Application

| Item # | Accessory |
|--------|-----------|
| 1 | |
| 2 | |
| | |

*Mandatory

Vehicle Service Parts (may be required for reassembly)

| Item # | Quantity Req'd. | Description |
|--------|-----------------|-------------|
| 1 | | |
| 2 | | |
| 3 | | |
| | | |

Legend

 **STOP:** Damage to the vehicle may occur. Do not proceed until process has been complied with.

 **OPERATOR SAFETY:** Use caution to avoid risk of injury.

 **CAUTION:** A process that must be carefully observed in order to reduce the risk of damage to the accessory/vehicle and to ensure a quality installation.

 **TOOLS & EQUIPMENT:** Used in Figures calls out the specific tools and equipment recommended for this process.

 **REVISION MARK:** This mark highlights a change in installation with respect to previous issue.

 **SAFETY TORQUE:** This mark indicates that torque is related to safety.



Care must be taken when installing this accessory to ensure damage does not occur to the vehicle. The installation of this accessory should follow approved guidelines to ensure a quality installation.

These guidelines can be found in the "Accessory Installation Practices" document.

This document covers such items as:-

- Vehicle Protection (use of covers and blankets, cleaning chemicals, etc.).
- Safety (eye protection, rechecking torque procedure, etc.).
- Vehicle Disassembly/Reassembly (panel removal, part storage, etc.).
- Electrical Component Disassembly/Reassembly (battery disconnection, connector removal, etc.).

Please see your Toyota dealer for a copy of this document.

1. Prepare for the Install.

- (a) Open the box and check the kit for complete contents and any damage.
- (b) Use a panel pry tool to remove and discard the twelve (12) OE plastic plug bolts from underneath the vehicle, 6 per side (Fig. 1-1).

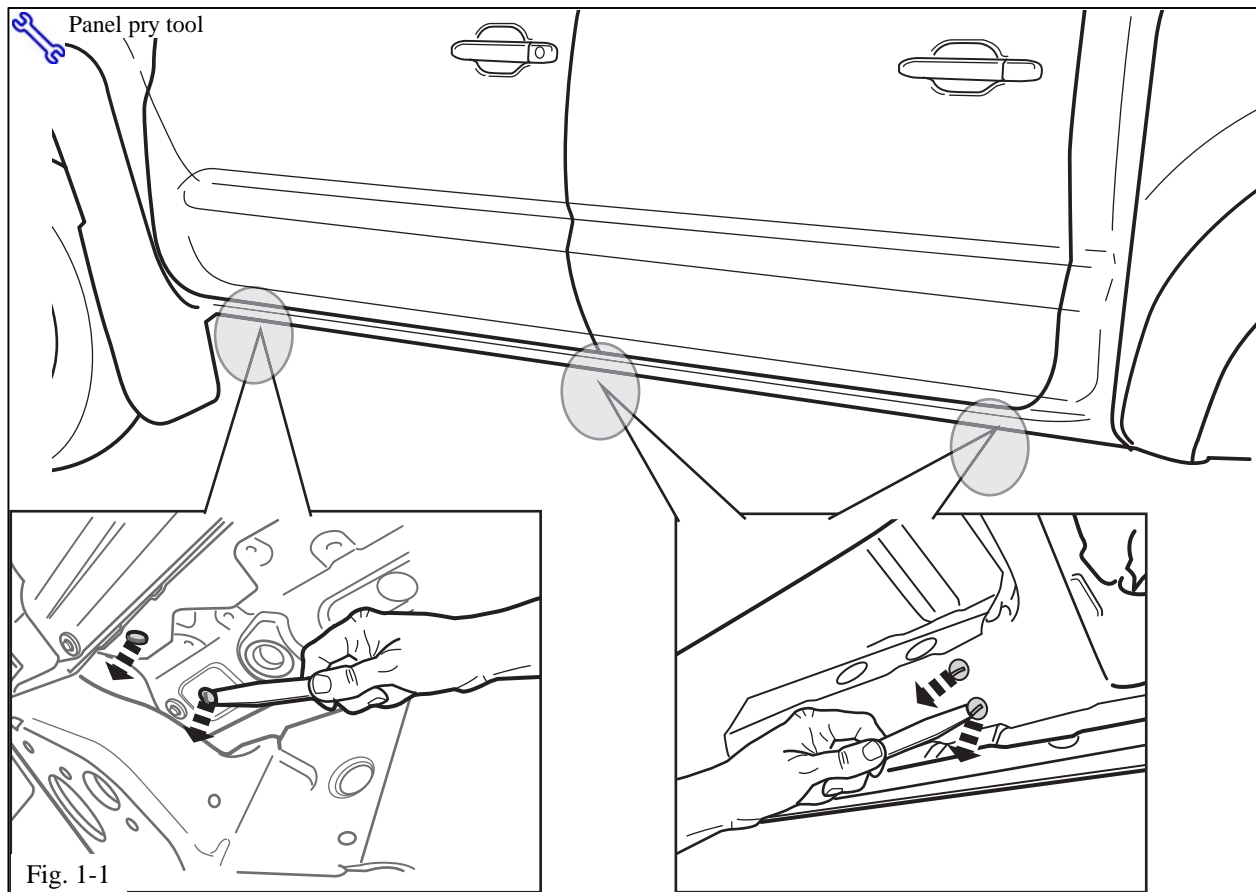

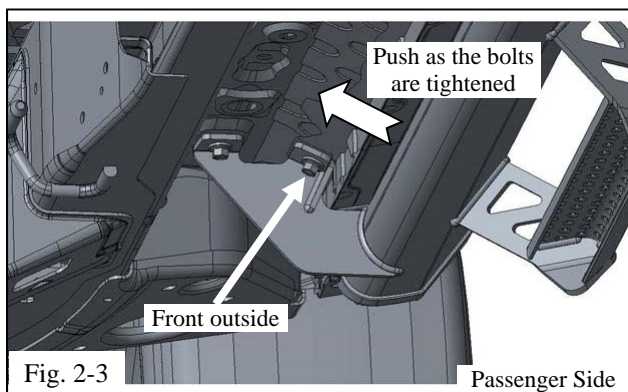
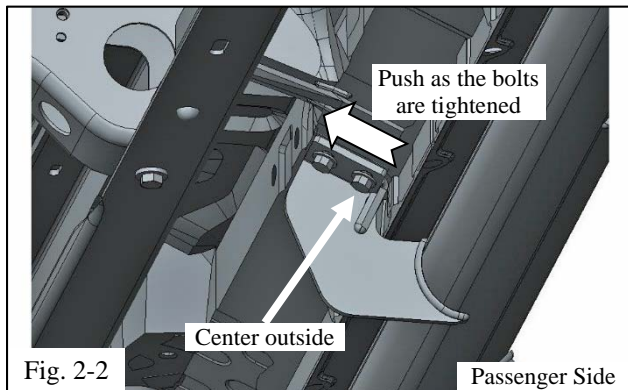
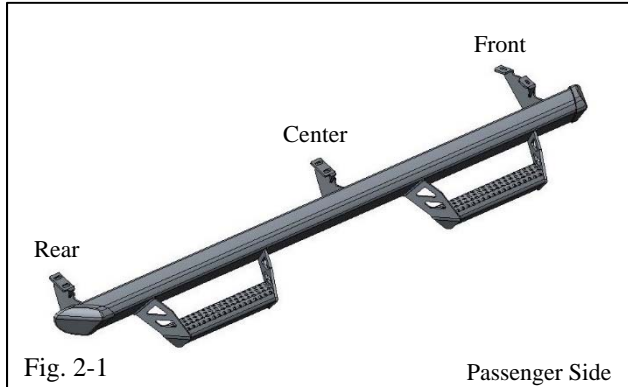

2. Install the Passenger Side Tube Step.

- (a) Position the tube step to the passenger side of the vehicle.

⚠ NOTE: The long bracket goes to the front of the vehicle (Fig. 2-1).

⚠ NOTE: For the following steps, the use of a non-impacting type electric hand tool can be used to drive the bolts so long as the bolt does not reach or exceed the specified torque. **Leave all hardware loose at this time.**

- (b) Start one 8mm bolt into the outside slotted hole in the center bracket (Fig. 2-2).

- (c) Start one 8mm bolt into the outside slotted hole in the rear bracket.

- (d) Start one 8mm bolt into the “outside” hole in the front bracket (Fig. 2-3).

- (e) Start the remaining 8mm bolts, starting with the front bracket working to the rear.

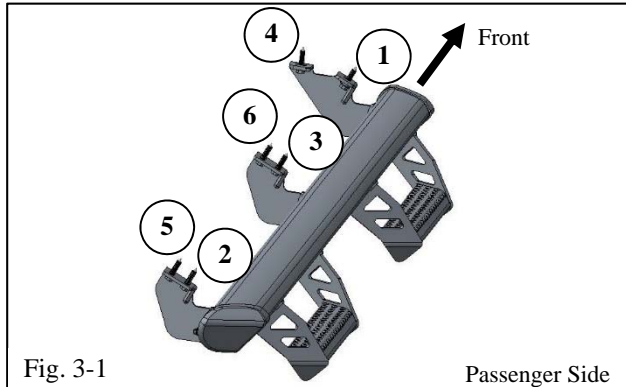

3. Tighten all Hardware.

- (a) Tighten (but do not torque) the front outside bolt (1), then the rear outside bolt (2), and finally the center outside bolt (3) (closest to the pinch weld) (Fig. 3-1).

⚠ NOTE: As the bolts closest to the pinch weld are tightened, push the bracket inward to maximize clearance to the pinch weld.

- (b) Tighten (but do not torque) the remaining bolts as indicated in Fig. 3-1.

4. Torque all Hardware.

- (a) Follow the tightening sequence in Fig. 3-1 to torque the “outside bolts” (1) through (3).

⚠ Torque: 23 N-m (17 ft-lbf)

- (b) Follow the tightening sequence in Fig. 3-1 to torque the “inside bolts” (4) through (6).

⚠ Torque: 23 N-m (17 ft-lbf)

5. Install the Driver Side Tube Step.

- (a) Repeat Steps 2 through 4 on the driver side.

6. Re-torque all Hardware.

- (a) Re-torque all twelve 8mm Hex Bolts in the same order as Step 4.

⚠ Torque: 23 N-m (17 ft-lbf)

Checklist - these points **MUST** be checked to ensure a quality installation.

| <u>Check:</u> | <u>Look For:</u> |
|---|---|
| <p><u>Accessory Function Checks</u></p> <ul style="list-style-type: none"> <input type="checkbox"/> Step alignment & torque <input type="checkbox"/> Inspect bolt torques <input type="checkbox"/> <input type="checkbox"/> | <p>Torque: 23 N-m (17 ft-lbf)</p> <p>Complete the torque audit sheet</p> |
| <p><u>Vehicle Function Checks</u></p> <ul style="list-style-type: none"> <input type="checkbox"/> No interference between step & vehicle <input type="checkbox"/> <input type="checkbox"/> | <p>Pinch weld contact</p> |
| <p><u>Vehicle Appearance Check</u></p> <ul style="list-style-type: none"> <input type="checkbox"/> After accessory installation and removal of protective cover(s), perform a visual inspection. | <p>Ensure no damage (including scuffs and scratches) was caused during the installation process. (For PPO installations, refer to TMS Accessory Quality Shipping Standard.)</p> |